

WIEGO SOCIAL PROTECTION PROGRAMME: OCCUPATIONAL HEALTH AND SAFETY PROJECT THE IMAGINE DURBAN CARDBOARD RECYCLING PROJECT



Implemented by



asiye
etafuleni

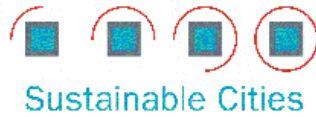



ImagineDurban
Ake Sicabange ngeTheku



Sustainable Cities



PLUSnetwork



asiye
etafuleni



1



2



3



4



5



8



7



6



9

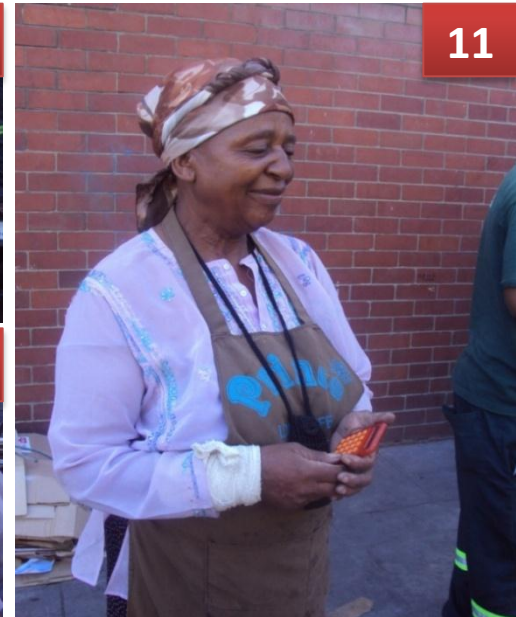

11



12



10

UNION STREET
COLLECTION POINT



PINE STREET COLLECTION POINT



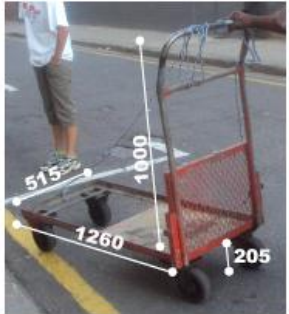

- Exposure to dirt, pollution & the elements
- Heavy loads on head
- Walking long distances
- Inability to afford trolleys
- Scarcity of cardboard supply
- Theft of cardboard
- Exploitation by some 'middle-men'
- Lack of recognition from city officials for service provided

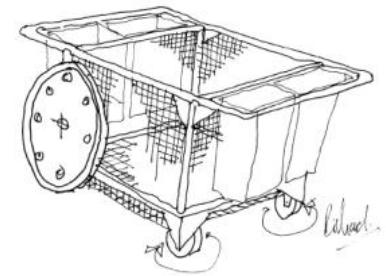
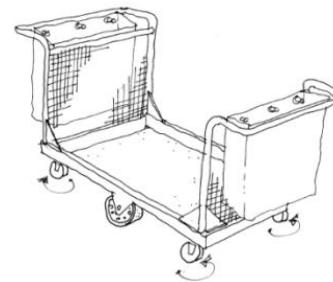
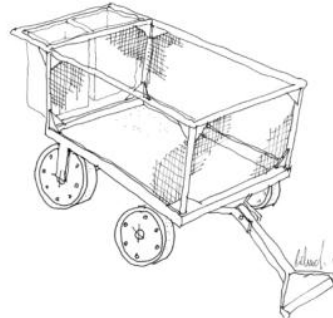
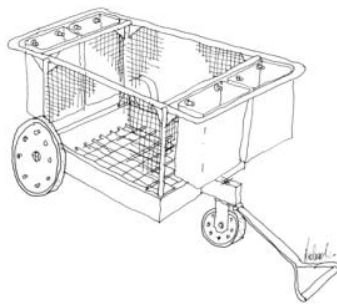
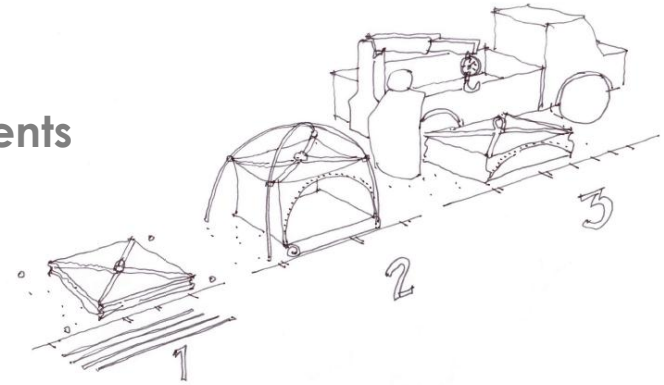

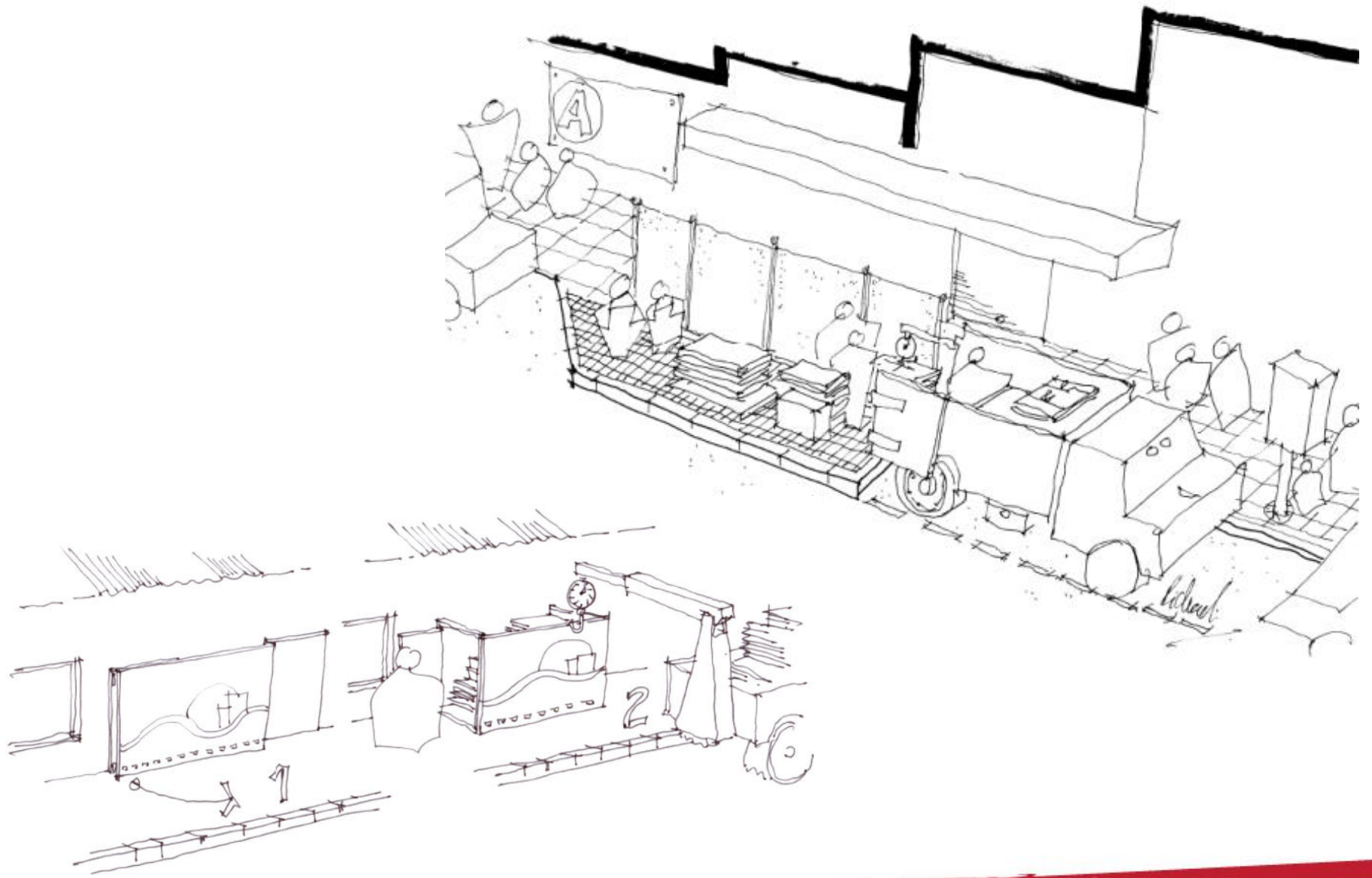

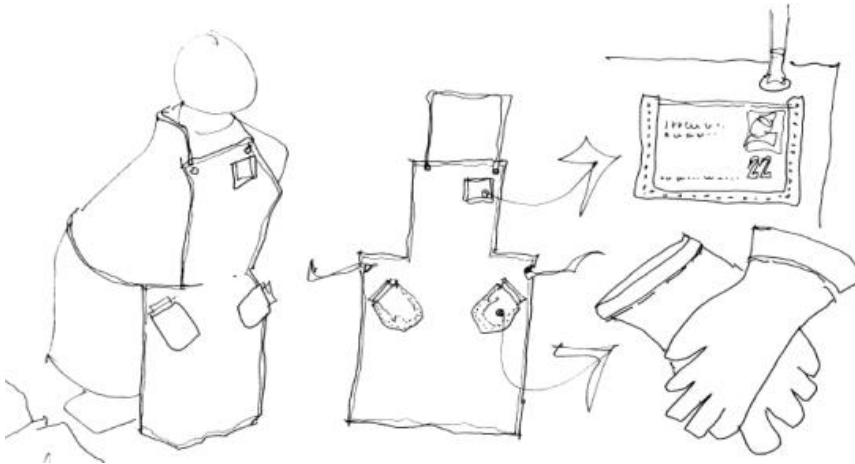

'FRIENDS OF THE RECYCLERS'

Invitation to Formal Businesses to participate.

Initiating sustainable practices in our city is becoming a necessity and we as citizens of eThekweni need to embrace sustainable development.

A Long Term Plan for the city has been developed and adopted by the eThekweni Municipality's Council to inspire citizens, non-governmental organisations, business and government to work together, take ownership of a set of action areas to build a caring and liveable city.

As part of the implementation phase of the plan, the NGO, Asiye eTafuleni has been commissioned by eThekweni Municipality through its Imagine Durban Demonstration Fund, a joint initiative between the Municipality and Sustainable Cities, a Vancouver based NGO (Canada), to implement an inner city cardboard recycling project.

The project is aimed at testing methods of improving the livelihoods of informal cardboard recyclers and better manage the cardboard collection process within the public realm. Asiye eTafuleni will be piloting the project with the distribution of custom-designed trolleys and equipment to a group of identified beneficiaries, some of which are depicted here:

As part of the pilot phase, we invite formal businesses to participate in the exciting opportunity to donate their cardboard and paper waste to Imagine Durban cardboard recyclers. You as a formal business stand to gain in the following ways:

- Waste recycling and thereby contributing to a zero-waste environment
- Improving the livelihoods of Cardboard Recyclers
- A certificate of recognition signed by the City Manager & the Director of Sustainable Cities (Canada)

During the 3 month process a formal evaluation of this 'Friends of the Recyclers' initiative will be carried out, so that the most positive aspects may be implemented on a more formalised basis and extended to as many businesses as possible.

If you would like to be involved in this initiative or for more information, please feel free to contact Tazmi Quazi on (031) 309 3880 or email tazmi@act.org.za and visit our website: www.imaginedurban.org



EQUIPMENT

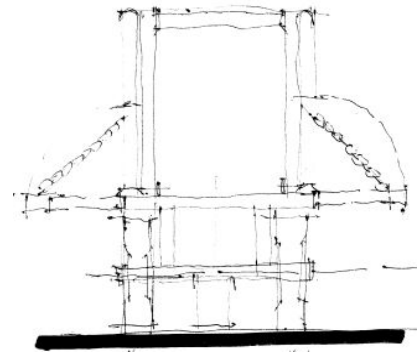
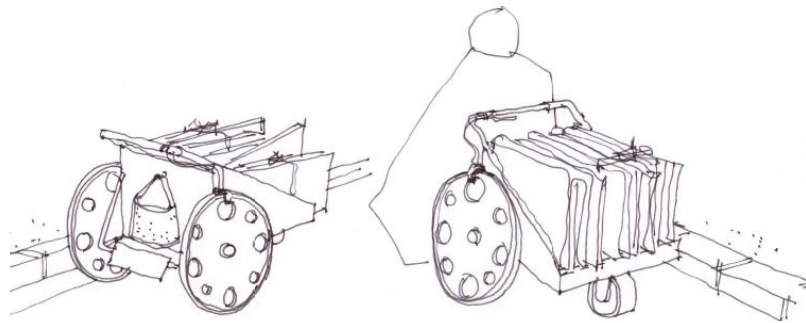
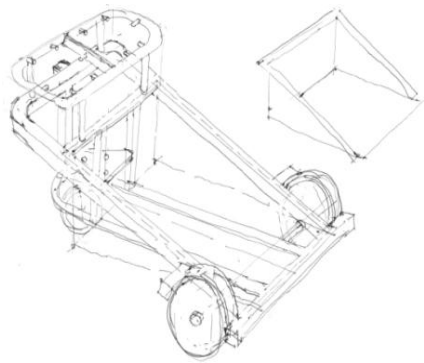

Different locations
Different challenges
Different opportunities

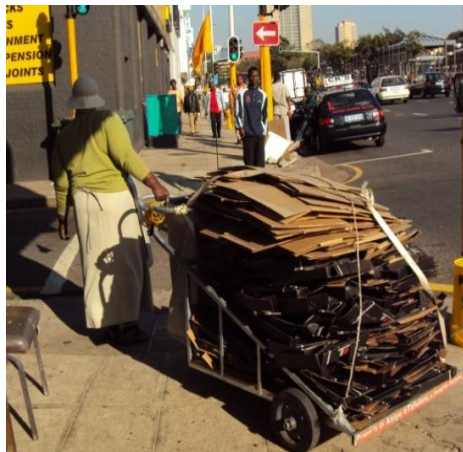
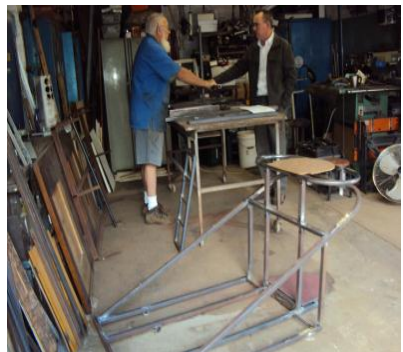

CONVEYANCE



ImagineDurban
Ake Sicabange ngeTheku



Sustainable Cities



LIST OF RECYCLING COLLECTION AGENTS FOR INFORMAL RECYCLERS



Item	Collector	Contact
CARDBOARD	Ubunle Bekusasa Recycling (UBR)	072 500 2111 (Zwell)
	Babs	031 461 5241 (Fahim) 082 446 5173 (Babs)
	Reclamation	031 465 2060
	Mondi	031 274 6600 (Debby)
	South African Waste Papers	078 178 3414 (Busiswe Veezi)
	Cardboard King	031 569 4575
	Evergreen	031 566 7498
WHITE/OFFICE PAPER	Babs	031 461 5241 (Fahim) 082 446 5173 (Babs)
	Reclamation	031 465 2060
	Mondi	031 274 6600 (Debby)
	Premiere Waste Recyclers	031 5001813/ 063 701 6383
NEWSPAPERS	Babs	031 461 5241 (Fahim) 082 446 5173 (Babs)
	Mondi	031 274 6600 (Debby)
	Premiere Waste Recyclers	031 5001813/ 063 701 6383
	Reclamation	031 465 2060
CLEAR PLASTIC	Babs	031 461 5241 (Fahim) 082 446 5173 (Babs)
	Reclamation	031 465 2060
	Premiere Waste Recyclers	031 5001813/ 063 701 6383
CANS	Collect-A-Can	031 700 6635

CALCULATING TABLE

		KILOGRAMS																			
c/kg	3	5	10	15	20	25	30	35	40	45	50	55	60	65	70	75	80	85	90	95	100
10	30c	50c	R 1	R1,50	R 2	R2,50	R 3	R3,50	R 4	R4,50	R 5	R5,50	R 6	R6,50	R 7	R7,50	R 8	R8,50	R 9	R9,50	R 10
15	45c	75c	R1,50	R2,25	R 3	R3,75	R4,50	R5,25	R 6	R6,75	R7,50	R8,25	R 9	R9,75	R10,50	R11,25	R 12	R12,75	R13,50	R14,25	R 15
20	60c	R 1	R 2	R 3	R 4	R 5	R 6	R 7	R 8	R 9	R 10	R 11	R 12	R 13	R 14	R 15	R 16	R 17	R 18	R 19	R 20
25	75c	R1,25	R2,50	R3,75	R 5	R6,25	R7,50	R8,75	R 10	R11,25	R12,50	R13,75	R 15	R16,25	R17,50	R18,75	R 20	R21,25	R22,50	R23,75	R 25
30	90c	R1,50	R 3	R4,50	R 6	R7,50	R 9	R10,50	R 12	R13,50	R 15	R16,50	R 18	R18,50	R 21	R22,50	R 24	R25,50	R 27	R28,50	R 30
35	R1,05	R1,75	R3,50	R5,25	R 7	R8,75	R10,50	R12,25	R 14	R15,75	R17,50	R19,50	R 21	R22,75	R24,50	R26,75	R 28	R29,75	R31,50	R33,75	R 35
40	R1,20	R 2	R 4	R 6	R 8	R 10	R 12	R 14	R 16	R 18	R 20	R 22	R 24	R 26	R 28	R 30	R 32	R 34	R 36	R 38	R 40
45	R1,35	R2,25	R4,50	R6,75	R 9	R11,75	R13,50	R15,75	R 18	R20,25	R22,50	R24,75	R 27	R29,25	R31,50	R33,75	R 36	R38,25	R40,50	R42,75	R 45
50	R1,50	R2,50	R 5	R7,50	R 10	R12,50	R 15	R17,50	R 20	R22,50	R 25	R27,50	R 30	R32,50	R 35	R37,50	R 40	R42,50	R 45	R47,50	R 50
55	R1,65	R2,75	R5,50	R8,25	R 11	R13,75	R16,50	R19,50	R 22	R24,75	R27,50	R30,25	R 33	R35,75	R38,50	R41,25	R 44	R46,75	R49,50	R52,25	R 55
60	R1,80	R 3	R 6	R 9	R 12	R 15	R 18	R 21	R 24	R 27	R 30	R 33	R 36	R 39	R 42	R 45	R 48	R 51	R 54	R 57	R 60
65	R1,95	R3,25	R6,50	R9,75	R 13	R15,25	R18,50	R22,75	R 26	R29,25	R32,50	R35,75	R 39	R42,25	R45,50	R48,75	R 52	R55,25	R58,50	R61,75	R 65
70	R2,10	R3,50	R 7	R10,50	R 14	R16,50	R 21	R24,50	R 28	R31,50	R 35	R38,50	R 42	R45,50	R 49	R52,50	R 56	R59,50	R 63	R66,50	R 70
75	R2,25	R3,75	R7,50	R11,25	R 15	R17,75	R22,50	R26,75	R 30	R33,75	R37,50	R41,25	R 45	R48,75	R52,50	R56,25	R 60	R63,75	R67,50	R71,25	R 75
80	R2,40	R 4	R 8	R 12	R 16	R 20	R 24	R 28	R 32	R 36	R 40	R 44	R 48	R 52	R 56	R 60	R 64	R 68	R 72	R 76	R 80
85	R2,55	R4,25	R8,50	R12,75	R 17	R21,25	R25,50	R29,75	R 34	R38,25	R42,50	R46,75	R 51	R55,25	R59,50	R63,75	R 68	R72,25	R76,50	R80,75	R 85
90	R2,70	R4,50	R 9	R13,50	R 18	R22,50	R 27	R31,50	R 36	R40,50	R 45	R49,50	R 54	R58,50	R 63	R67,50	R 72	R76,50	R 81	R85,50	R 90
95	R2,85	R4,75	R9,50	R14,25	R 19	R23,75	R28,50	R33,75	R 38	R42,75	R47,50	R52,25	R 57	R61,75	R66,50	R71,25	R 76	R80,75	R85,50	R90,25	R 95
R 1	R 3	R 5	R 10	R 15	R 20	R 25	R 30	R 35	R 40	R 45	R 50	R 55	R 60	R 65	R 70	R 75	R 80	R 85	R 90	R 95	R 100

FACILITATION

6 Upscaling & 2nd generation delivery

1 Research & Street work

5 Refining preferred designs

2 Identification of participants

3 Design research & development

4 Testing & Evaluation of proposed designs

