



Chapter 4

From street to informal shopping concourse:
urban design solutions

Chapter 4: From street to informal shopping concourse: urban design solutions

Chapter 1 described what it is like to walk into the Brook Street Market and look down onto its sea of colourful stalls, traders, pedestrians and shoppers. The conversion of what was once a congested and grimy street into an exciting, spacious, shopping concourse is one of the triumphs of the Warwick Junction Project.

The seven-year, phased redevelopment of Brook Street entailed both a macro- and micro-redesign of the area. It was where the Project team experimented most with different types of infrastructure for street traders. This chapter focuses on the urban design and architectural solutions that were developed through the Project team's work in this area and their implementation. It is hoped that some of the broader ideas emerging from the experience in Brook Street can be used and adapted by others working in this field.

Early Brook Street

A trader leader who has been working in Brook Street for over 10 years described the street before its development:

The area looked like a forest. There was a small path to walk through. The tables were covered in plastic and there were shacks everywhere. It was not safe to walk there.

The photos show Brook Street before it was developed. The street is sandwiched between the railway lines and Berea Station on one side and a cemetery and shrine on the other. Stairways from the station come straight down into the street, making it an obvious place to trade. The street had not been used by traffic for years.

Three religions are represented in the area around Brook Street. The Juma Masjid Mosque and the Emmanuel Catholic Cathedral are both on a street leading towards the market. The original city cemetery, where Muslim, Jewish and Christian people are buried, runs alongside Brook Street.



An aerial view of Brook Street before it was developed



Stairs used for clothes trading



Brook Street trading prior to the redevelopment



Badsha Peer shrine with traders in the foreground prior to the redevelopment



The first phase of the roof in Brook Street

One of the graves there is that of Badsha Peer, who came to Durban in 1860 as an indentured labourer. After five years he was discharged and soon became a leader of the Muslim faith and, on his death, an Islamic saint. Out of reverence for him and the many miracles attributed to him, the Muslim community erected a shrine in his memory, between the cemetery and Brook Street.

Since 1943 commemoration ceremonies have been held annually in Brook Street itself. Initially the Badsha Peer Mazaar Society erected marquees over the road to seat the large numbers attending. By arrangement traders demolished their stalls while the road was cleared and the marquees set up. They then returned for a few more days' trading and vacated their sites just before the ceremony. This mutual cooperation continued for many years and was encouraged by the Mazaar Society, which provided timber and nails for the re-erection of the stalls.

A joint venture to provide shelter in Brook Street

By 2000 the number of devotees had swelled to 10 000. The Mazaar Society was having great difficulty finding big enough marquees to seat everyone for the three-day ceremony. The Society approached the Project, offering to contribute towards the erection of a permanent roof next to the shrine. The area would be used for their ceremony but would otherwise serve as a covered trading space for informal traders. Although planning had already started on this project as the next phase in the regeneration of Warwick as a whole, the suggestion by the Mazaar Society provided the impetus to make an earlier start.

Joint ventures such as this present both opportunities and complications. The city wished to satisfy the needs of the Badsha Peer community yet at the same time ensure that for the other 362 days in the year the space could be used by a large number of street traders and pedestrians. Any new structure thus needed to fit in with a broader developmental vision for the area.

Balancing all of these interests required numerous meetings with street trader and Mazaar Society leaders as well as mass meetings with affected traders.

It was agreed that the Project team would take responsibility for building the shelter, the council would bear the costs and the Society would contribute to these. A commitment was made to have this first phase of the shelter ready for the Society's 60th anniversary celebrations and work began on this in 2000. In designing the shelter, the Project had to observe the stipulations in the bylaws regarding structures alongside and over any road. In complying with these, the width of the concourse and height of the shelter were defined.

In return for vacating the area for the period of the ceremony, Brook Street traders pay a slightly lower monthly rental. Their permits stipulate that they will vacate their sites when the ceremony is held.

One of the unique factors of the market is the way in which the Mazaar Society and the market's traders interact to the benefit of one another.

The market embodies the overall transformation goals of the Warwick Junction Project and the city. It is a place where different cultures cooperate around very different sets of objectives.

Project leader



The Badsha Peer religious ceremony in Brook Street

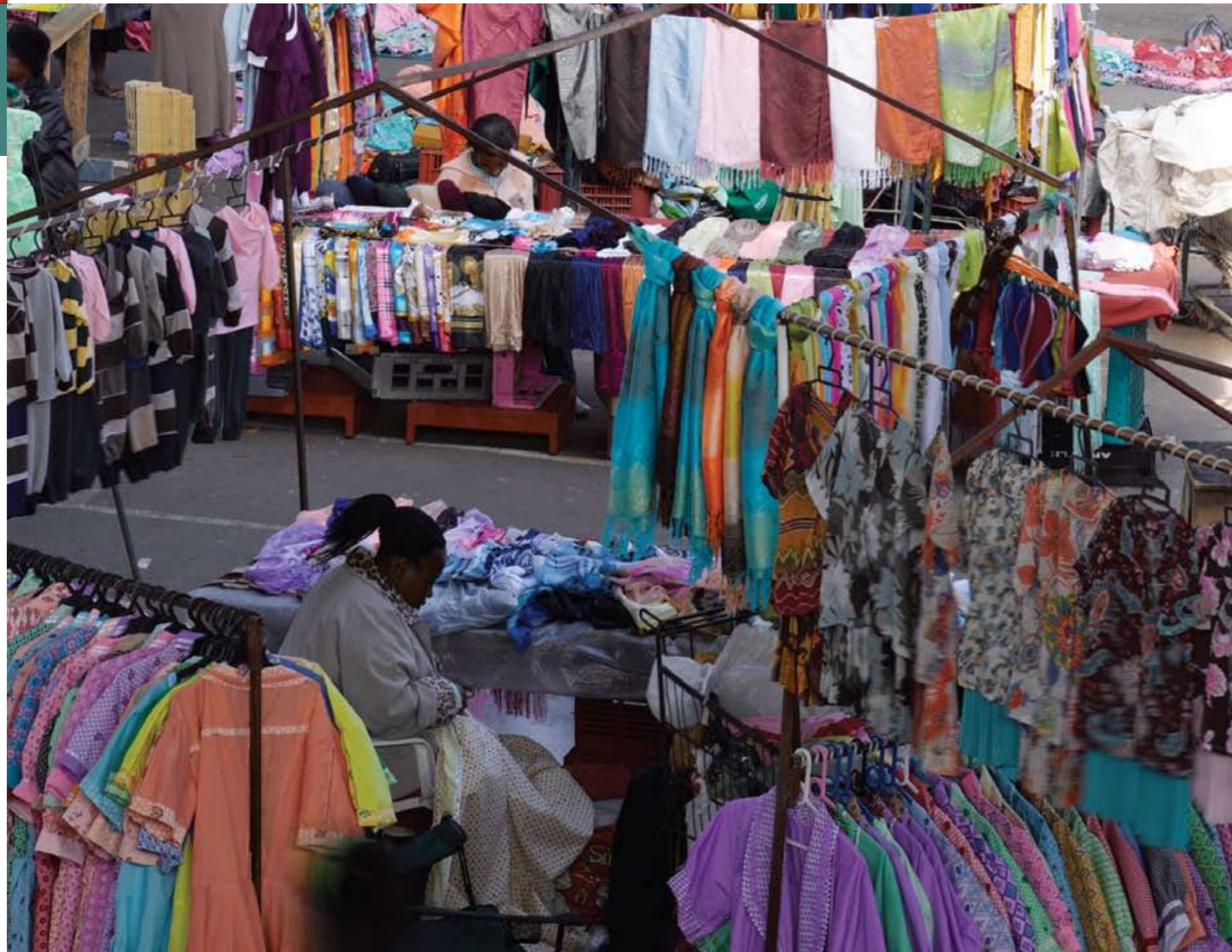

Selling pinafores and other clothing in Brook Street

WORKING AS A PINAFORE TRADER

Thembi Sithole

The pinafore trade in the Brook Street Market is extensive. Pinafores are very practical, especially for those engaged in rough and dirty work likely to damage more valuable clothing underneath. Photos of the bovine head sellers and other women traders are testimony to this. Pinafores are also used at ceremonies where *lobola* (bride wealth) is paid.

Thembi Sithole makes and sells pinafores in the Brook Street Market. In 1991 Thembi completed a dress-making course and has been trading in pinafores in and around Warwick ever since. Her customers are frequently people from other parts of the country who buy in bulk to sell elsewhere. She employs a woman who works and lives in the inner city where many small garment businesses have been established.

She feels that her pinafore trade has been a success as she has been able to put two sons and a daughter through school and further training. Two of them are teachers and one an electrician. She and her working children support a household of ten.

Thembi thinks that the new trading site in Warwick is an improvement on where she used to trade on a pavement. However, for other reasons business has gone down. Numbers of pinafore traders have doubled in the last five years, making the market much more competitive.

I used to come with a bag full of pinafores and go back home with my bag empty. I managed to put my children through school and paid for Tech (technical college) without a single loan. I would not be able to do that these days.

Pinafore traders used to be older women, but now they compete with younger people who have left school and have no work or others who have been retrenched from garment factories.

Like many other pinafore traders she buys her fabric from formal shops in the area but thinks that other traders are sourcing their fabric elsewhere, which enables them to reduce their prices and undercut traders like herself. The fabric used for pinafores is largely imported from the East. Traders used to agree on a price per pinafore and Thembi sold pinafores for R40. Now some traders manage to sell these for as little as R30.



Thembi Sithole feels that her pinafore trade has been a success as she has been able to put two sons and a daughter through school and further training.



The new space created by the changes described on page 93.

An overview of the major infrastructural changes

The Brook Street Market developed in six phases, over seven years and entailed redesigning the area completely.

Increased pedestrian walkways

A priority was that the new market should open up new pedestrian routes, widen walkways and ease congested trading conditions. The station alongside Brook Street had been designed in the days of apartheid. Three sets of stairs led immediately down from the station concourse, leaving pedestrians no alternative routes out of the station and over Brook Street. This design was intentional so that if necessary these exits could be blocked off to prevent commuters entering the inner city. Pedestrian movement was severely restricted. This prolonged commuting time, and meant that trading spaces were congested and pedestrians more vulnerable to criminals.

The Project undertook to remove the east end of one of the disused freeways that sloped low over Brook Street and all but closed off pedestrian traffic at this end: an enormous undertaking.

Other walkways that further increased pedestrian choices were a curved pedestrian bridge from the *Muthi* Market over Brook Street and a mezzanine floor that linked the three stairways, giving pedestrians an option to move above Brook Street to other exits.

Unlike typical market halls the movement of people passing is channeled through curved walkways at several levels, offering different views of the busy and ever-changing scene.

Keith Hart

These changes impacted on traders in important ways: the trading environment improved as the number of possible routes for pedestrians meant that traders did not need to congregate around a few exit points; the opening up of congested areas made cleaning easier and health conditions improved; and canyons were removed which reduced opportunities for criminals.



The demolition of the end of the disused freeway



The installation of a pedestrian bridge



Kiosks in Brook Street

Other improvements to trading conditions and opportunities

The area was paved, a move that immediately made trading conditions less dusty and dirty. A more time-consuming exercise was extending the Mazaar Society shelter to cover a much bigger area. The roof, which now extends over 200 metres, was constructed over three years in three different phases and provides shelter for both street traders and the thousands of pedestrians who use the area every day.

Storage was one of the immediate challenges. Facilities were built along one side of Brook Street and the shipping containers that had been used for storage were removed. This opened up trading space considerably.

Another aspect of the redesign was the construction of trader kiosks, a new feature for Warwick. Some, appropriate for catering purposes, opened out onto the new mezzanine floor where a vibrant informal food court emerged. Others were built at one end of the Traditional Medicine Market for healers and for small scale manufacturing activities. Water and electricity are provided in these kiosks.

Space was developed under the highway bridges for a wholesale clay market, and a facility established for pinafore and bead traders.



A trader's goods packed for storage



How the team went about its work

Again, the expertise within council departments was vital. As outlined in the box below, the Project team consisted of officials drawn from the many different council departments.

- PROJECT STAFF WORKED AS A TEAM WITH OFFICIALS FROM:**
- Architecture and Buildings
 - Business Support
 - Cemeteries
 - City Health
 - Emergency Services (Fire)
 - eThekweni Transport Authority
 - Intersite (the property division of the Metro Rail, the commuter rail company)
 - Real Estate
 - Urban Design

The implementation team started with very careful observation of how pedestrians were moving through the area and the nature of the trading activities there.

The design challenge was always to maintain the vibrancy, but, by subtly diluting the pedestrian concentrations, provide more trading opportunities. You could only do this by carefully observing what was going on and predicting the response to the proposed redesign.

Project leader

Through their observations the Project team also had to assess some hard facts, such as how many traders could operate viably in the area. The volume of ‘passing feet’ determines how lucrative a trading site is. On the one hand local governments have a responsibility to spread the gains from this use of public space rather than limiting them to a few traders. On the other hand however, given the limited income of poorer commuters in areas like Warwick, if there are too many traders none of

them will earn a decent living. Local government officials thus have to make careful calculations of what the optimum street trader carrying capacity of any particular street is. This calculation will always be context specific. It will depend on the numbers of pedestrians and the spatial design of the area, for example how wide the pavements are.

In Brook Street the redevelopment did increase the total number of traders operating. Consequently some traders reported that their incomes decreased. Given the numbers of commuters passing through the area the Project team concluded that the area could satisfy the needs of the additional traders.

The Project team realized that phased redevelopment was, in general, a useful way to work. As the Project leader noted:

The fact that the market was developed in six phases gave planners an opportunity to review each stage and its impact on traders and to make adjustments if necessary.

FACTORS TO CONSIDER IN THE SPATIAL REDESIGN FOR THE INFORMAL ECONOMY

- Any urban redesign needs to be informed by the nature of existing trading activities – what is sold where and how it is displayed, as well as pedestrian flows.
- Pedestrian counts are important in calculating how many street traders can be accommodated in any one area. Although there may be no official figures, transport authorities normally have estimates. If these are not available then estimates can be made by spending time on the streets.
- The viability of the majority of street trading businesses is about ‘passing feet’. Any redesign that changes pedestrian flows needs to bear this in mind.
- Certain trades are not so dependent on foot traffic. Trades where customers specifically seek out products or services can be accommodated in less busy areas.

Consulting and negotiating

Some of the broad consultation principles mentioned in Chapters 2 and 3 apply here as well. This section looks at some of the ways that consultation took place as the Market developed.

Before the start of each phase of the development a wide range of stakeholders was consulted, including street traders, their organisations and the Mazaar Society.

Once an initial design was ready, Project staff and the area manager from Business Support began presentations and discussions with traders and their leaders. These took place at a number of levels, starting with more formal presentations of the drawings, followed by on-site presentations where the new plans could be demonstrated visually. The area manager and a liaison officer spent hours each day on the street, engaging one-on-one with traders, helping to clarify issues and allowing concerns to surface.

The construction phase entailed a good deal of negotiation as inevitably traders were disrupted. There were detailed individual negotiations with traders to try to make sure that their new temporary location was situated on a site that provided trading opportunities similar to those they had had before. This was also important in maintaining the trust of traders. Another important issue was keeping to the agreed construction schedule. If there were delays these were communicated early. Trader representatives were also given periodic tours of the construction site so they could witness the progress first hand.

An indication of the extent to which traders were prepared to cooperate with the reconstruction was the way in which they worked with the contractor on day-to-day logistical issues. A committee of traders was set up to assist the contractor. This group would, for example, negotiate with the taxi rank associations to ensure that taxis did not block access when construction material was being delivered. The Project leader commented:

A contractor would arrive and take one look at the congestion in the area and wonder why he had tendered for the work! After a few weeks, amazed at the co-operation he was receiving, he would inevitably become the local ambassador for the area.

There was a lot of trial and error in the redesign process. For example traders were adamant that the Project team’s initial proposal about the



configuration of trading spaces under the new Brook Street shelter would not work. The Project team agreed to mark the spaces on the street and then get feedback from the traders about the problems. It was soon obvious that one group of traders would be operating in the storm water drains! If the Project team had ignored the traders and painted the sites as proposed, time and resources would have been wasted. Unconventional methods often work in seeking to understand fully why traders are not buying into what appears to be a viable proposal.

You have to be humble enough to learn from the traders and from the logic of the existing activities there.

Project leader



Trader storage before the project interventions

Trader storage

Well located and designed storage facilities benefit both traders and local government. They are convenient for traders; they change the amount and range of goods traders can display and sell; and they reduce damage to goods and therefore help to increase trader incomes. For some this also means that they do not have to sleep in the streets to guard their goods. For local government these storage facilities help to solve the problem of pavement sleeping, make pavements easier to clean (which reduces health risks) and improve the general appearance of the city.

For these reasons storage was placed high on the list for infrastructure at Brook Street.

Before it became a market, storage facilities around Brook Street were mainly recycled shipping containers situated on sidewalks. They obstructed sidewalks and, as people also slept in them, they were difficult to keep clean.

Storage is a business in its own right, as traders pay the storage operator for overnight storage space. Operators can make as much as R8 000 a month.

In the reconstruction of Brook Street twelve storage facilities of various sizes were built and the operators of the old containers were given the first option to lease the new storage units.

Traders' criteria for storage

Traders have identified four essential criteria for a storage facility. It should be:

- Affordable: only a small portion of traders' total income should be charged.
- Safe: the area should be well lit, locked and policed.
- Accessible:
 - Storage should be close to the trading site or place of overnight accommodation.
 - It should be easy to store goods already loaded onto a barrow, without off-loading them, and there should be enough space so the barrow can easily be taken out in the morning.
 - It should be open early and close late to allow for long trading hours.
 - It should be open over weekends and public holidays.
- Clean and well maintained: storage space should be suitable for

storing goods so that they do not get damaged by unhygienic conditions such as the presence of rats and cockroaches. Dampness, poor ventilation, cramped space and leaking roofs all contribute to damaging goods.

Source: Motala and Xhakasa (2001).

Design considerations

Trolley and barrow operators bring most of the goods to the storage facility. The goods arrive in a variety of shapes and sizes: in boxes and bags (clothes), metal trunks (higher value goods like music and cell phone accessories), heavy wooden crates (hardware) and large wooden packing cases (cook's equipment). Then there are bulky tables of many shapes and sizes and often awkward gazebos that the hair cutters use. The value of goods being stored also varies dramatically.

Accommodating all this is complicated by the fact that some of the goods come into the storage facility as late as 9.00 at night and often those brought in early need to leave first – as early as 4.00 in the morning – so cannot be cornered in at the back of the facility. The potential for a trolley traffic jam is high! Storage managers know all their customers personally (and their trolleys) and make careful calculations about how to ensure a smooth operation.

Taking all of the above into consideration, the Project designed the facilities as follows:

- All units have ramped entrances.
- In the bigger units – designed for larger goods – there is an open space where goods that are being stored can be moved in and out.
- The corners in the storage units were reinforced with steel to try and reduce the damage caused from the movement of goods in and out.
- Toilet facilities are provided.
- Electricity is provided. Without the provision of electricity candles and paraffin would have been used for lighting and heating and these are fire hazards.



New trader storage facilities



Street trader sites, tables and shelters

Sites

Traders' usage of their space varies enormously depending on how they want to display their goods and what space they need to work in. In Brook Street, for example, traders display their goods in a variety of ways. Bead sellers and second hand clothes sellers prefer to display their goods on the floor. Those selling peanuts and sweets often sell at knee height – well designed to catch the eyes of children. Those selling clothes often hang them from metal frames.

The issue of the size of site was much debated among Project staff and traders. Since different trades have different space needs, some argued that a variety of different sizes should be considered. Traders rejected this idea, since those with bigger sites could display more goods and would thus have an unfair business advantage. In the end most sites in Brook Street, and in the rest of Warwick, are two metres by one metre.

Tables

Trader tables were also a controversial issue: they can get in the way of the street cleaners and are potential health hazards for customers if they cannot be kept clean. Having uniform tables is another factor and is important for the aesthetics of an area. Some officials had initially argued that traders selling food should have steel tables. But these were heavy, difficult to transport and expensive - which made them worth stealing. In Brook Street, and throughout Warwick, it was agreed traders must be able to fold away tables at night, stacked in prearranged places so that the pavement could be freed up for thorough sweeping and occasional pressure cleaning. In addition any tables used for selling fresh produce should be covered with impervious plastic tablecloths.

Most traders now buy their tables from the local furniture maker in the area. They are made of wood and are light, inexpensive and easy to transport.

The first tables were made of concrete with steel lock-up cupboards underneath for storage. The cupboards were soon broken into as they gave the impression that they contained items of value. After several attempts at replacing the locks the tables were left with open cupboards beneath them. This encouraged people to sleep in them, which created health and cleanliness problems. Finally it was decided to build tables

with counters and no enclosed space beneath them. During the day the space was used for storage, but not at night. This final solution for the design of tables was arrived at through trial and error.

Shelters

By 2004 many Brook Street traders were in the unusual position of operating under what was effectively a huge market roof. The end of the market that was not covered was identified as an ideal site for pinafore sellers. The Project experimented here and elsewhere in Warwick with the design of street trader shelters. Again the approach of the Project was to observe how traders used their existing sites, and ask lots of questions. For designing shelters, the direction of the sun at different times of day as well as the direction of the rain were considered.

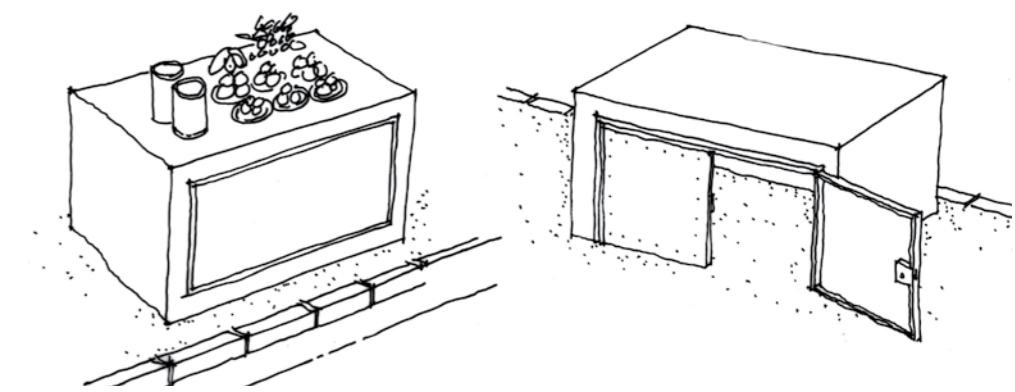

Trader table with lock up cupboards
which were broken into

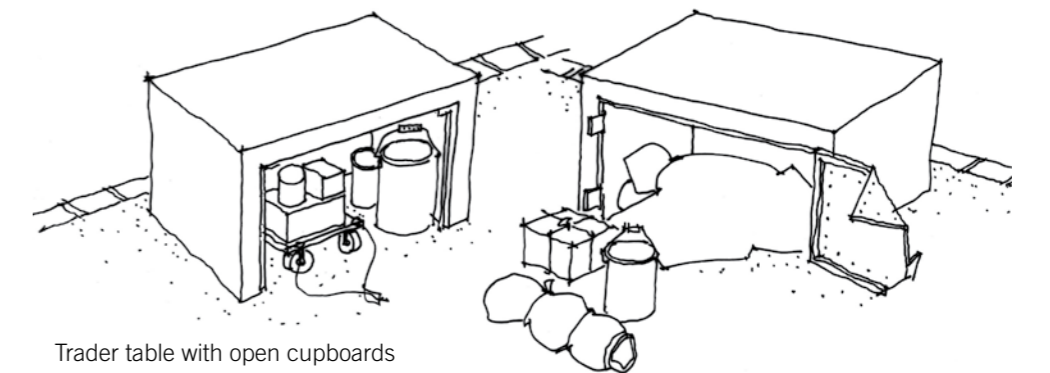

Trader table with open cupboards
but people slept in these

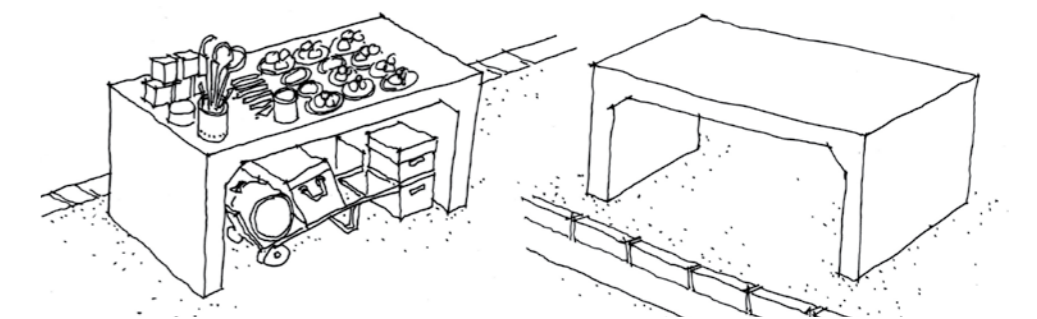

Trader table with no enclosed space
underneath, the final solution

Street trader table design by trial and error





The Friday wholesale bead and craft market

WORKING AS A BEAD WHOLESALER

Thobile Cele

Bead products are rooted in long established traditions of African dress and it is often older women who are involved in this work. Although now sold mostly as tourist items, the trade still retains the dignity of this ancient skill.

Thobile Cele has been selling her beads for nine years. She is 47 years old and lives about an hour and a half away from Durban. She trades mainly as a wholesaler, selling to the two other main groups of bead traders in Durban – along the beachfront and at the Durban Station. While the retail groups sell every day, Thobile and about 80 other women in Brook Street trade on Fridays only. During the rest of the week she designs and threads the beautiful beadwork that she spreads out at the bead traders' site in Brook Street. When asked whether anyone had assisted her with her design skills Thobile said,

No. I look at what others are making and if it's nice and sells well then I try to make it as well. I see things on TV or in magazines and make them. Sometimes I'd be sleeping and dream of something, when I wake up I'd start making that design.

As a wholesaler she does not rely strongly on 'passing feet' but it is important that her customers know where to find her. For this reason she was initially reluctant to move to Brook Street, even though her trading site at that time was a muddy bank beside a busy highway. However, when taxi drivers began insisting on a taxi rank where Thobile and other bead sellers were trading, they realised that their old trading spot was going to lose its appeal to their customers and that they would have to go.

Like other traders in Warwick, such as the pinafore sellers, Thobile sources her beads from formal businesses, mainly in the Grey Street area. They, in turn, import the beads from the Czech Republic and Taiwan. This links her into a formal business and her income depends on prices set outside the country. Thobile feels that it is the retailers who really make the profits in the trade. A necklace sold for R70 would have cost R30 in beads, but the retailers elsewhere sell this for R250.

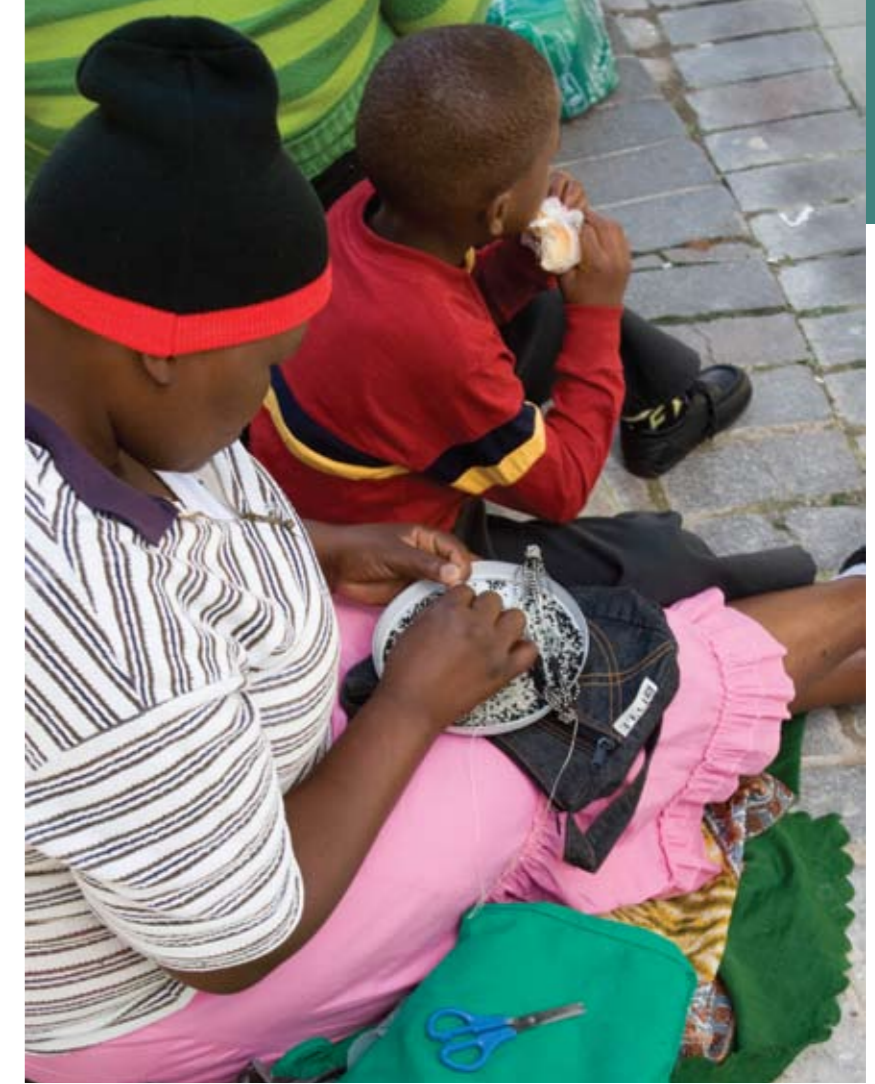

Like other traders in Warwick, such as the pinafore sellers, Thobile sources her beads from formal businesses



A kiosk used for catering

Providing more sophisticated infrastructure – trading kiosks, with water and electricity

Trader kiosks are an important feature of the Brook Street Market and are rare in South Africa. In all, sixty have been built in Warwick, all a standard design – about the size of an average single garage and fitted with strong metal roll down doors. Traders have adapted them to their needs: for example, traditional healers have divided theirs in half so that they can have a waiting room and a more private consultation and dispensing area. Many traders whose kiosks contain more expensive equipment have added security doors.

All kiosks are fitted with water, and over time pre-paid electricity meters have been fitted. Providing electricity was a major logistical challenge but a necessary one as traders were connected illegally to electricity points in the station, leaving a dangerous maze of electrical cables and extension cords running through the area. The city covered the costs of installing the pre-paid meters in each stall.

The first kiosks were developed for the traditional healers, providing a more appropriate place for them to consult with their patients. One kiosk was allocated to a communal processing machine for traditional medicines.

Another set of kiosks was designed as small kitchens for traders who had been cooking on the pavements using unprotected pots of boiling water and hot coals. They needed water drainage and electricity and particularly good security for valuable equipment such as stoves, fridges and pots. They also wanted a serving space, with tables and chairs for sit-down meals.

A final set of kiosks is used for manufacturing activities and people who provide essential services to the traders. There is the carpenter who specializes in trader tables and stools and there is also a battery charging outlet, as well as a specialized hi-fi equipment repairman who services the music traders.

Kiosks offer important economic advantages to traders. Given

their size they increase the quantity of stock that traders can carry and, as they can be closed and locked at night, they double up as storage units. This saves both storage costs and time that would otherwise be spent packing and unpacking goods and setting up stalls. Kiosk owners can then have longer trading hours. If electricity and water are provided they allow for much more sophisticated and lucrative activities – like catering and manufacturing.

Since getting my own kiosk I can now store goods worth almost R30 000.

Traditional medicine trader

Looking back

Officials working in Brook Street observed how providing infrastructure changed the nature of street trading activities. For example, if goods are protected from the weather and traders have access to secure storage, they start to trade in higher value goods.

If they have kiosks and thus bigger spaces they can trade and store a greater quantity and variety of goods, and if they have access to basic services like water and electricity they can start more lucrative trades, like catering and sewing. As the Project leader noted:

Investing in infrastructure is definitely one of the most influential routes to change the fortunes of the informal economy.

What the redesign process also demonstrated was the importance of continuous negotiation and consultation.

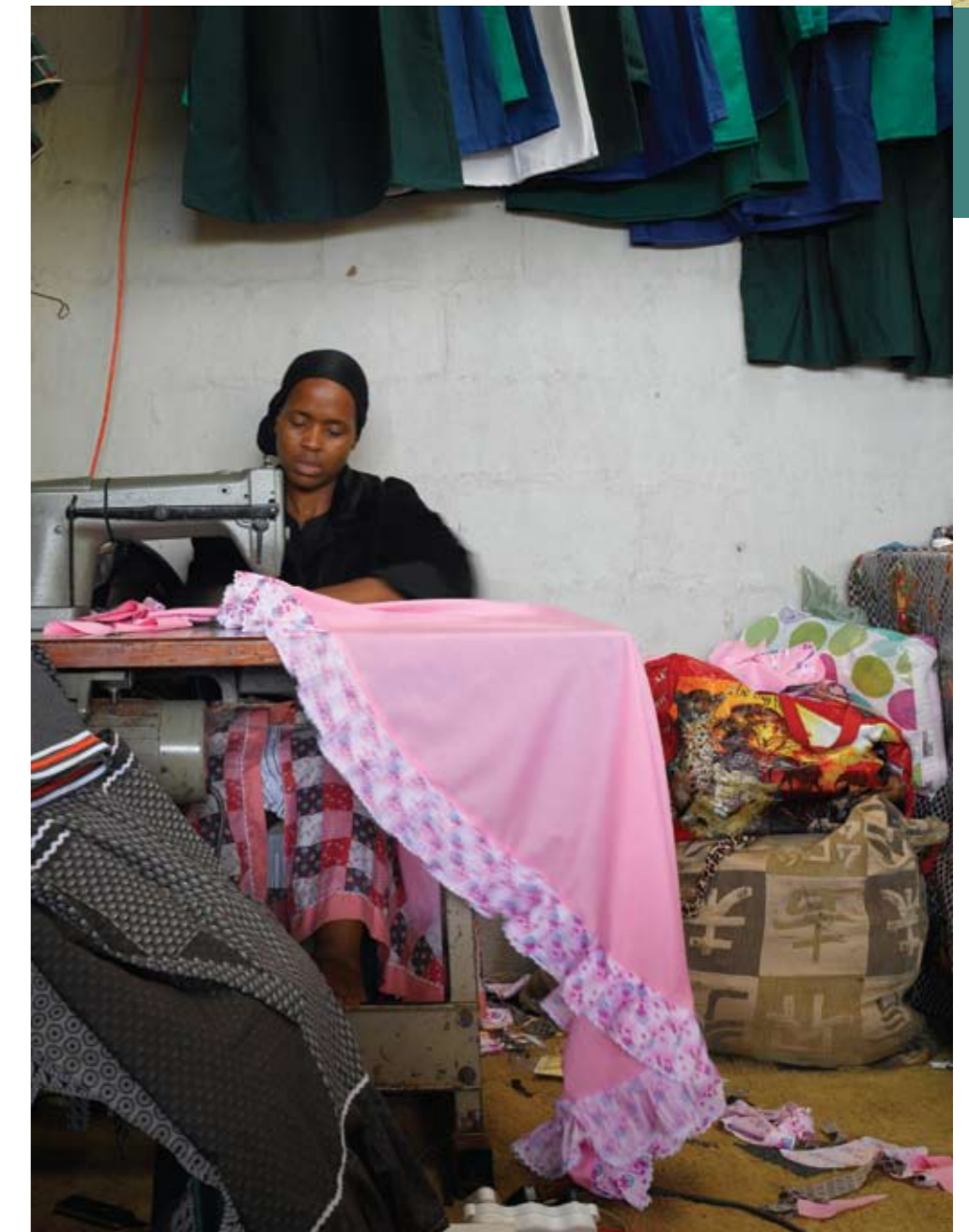

A kiosk used for dress-making